

Application Note - Powering Options

This document describes how to modify a SpaceLogger-RS circuit board may be to enable power out via a fused link through terminals 1 and 2.

The standard circuit board has LK1 made; therefore when power is supplied via the DC socket or terminals 1 and 2, power out via terminals 1 and 2 is not available.

When the circuit board is modified, with LK2 made and LK1 removed, a fused output is available via terminals 1 and 2. This fused output can be used for powering a WindSonic sensor or other any other compatible device.

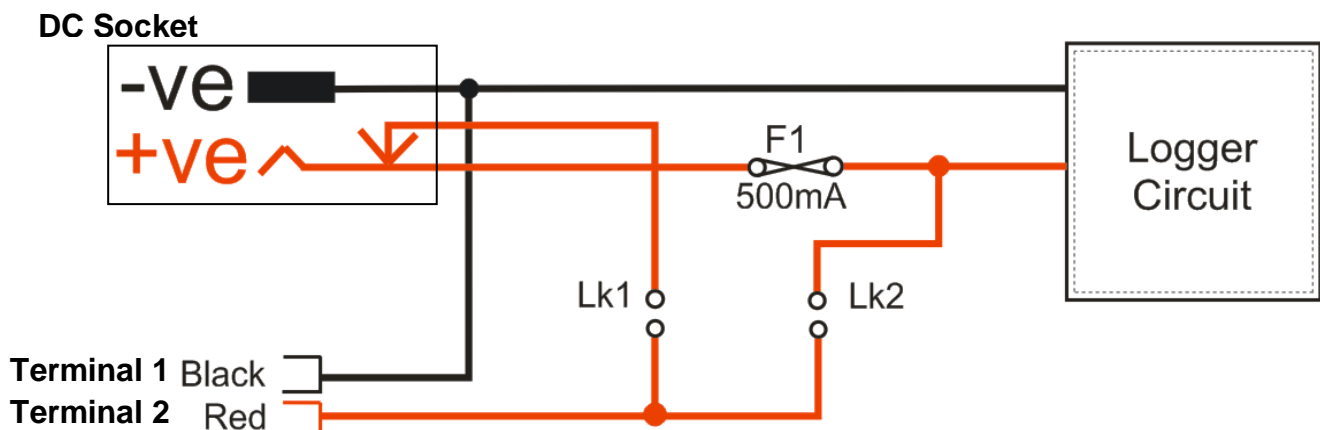
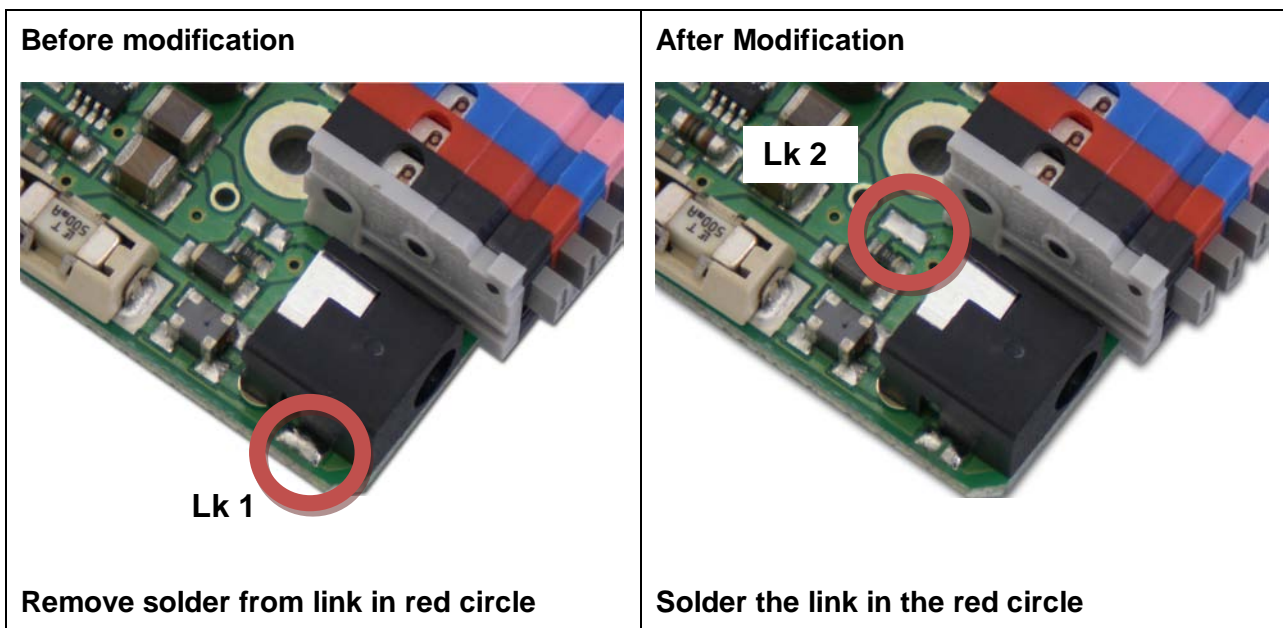

Please note that this work should only be carried out by a competent technician, any damage caused to the circuit board during this modification will void the warranty of the SpaceLogger-RS.